

# 15DZ

## Hand Load Cartoner

**ADCO**  
where products meet packaging

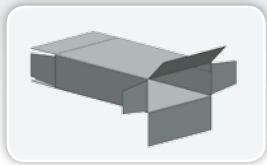

where products meet packaging™

Featuring a smooth and efficient single-head rotary carton feed system, the 15DZ delivers class-leading carton erecting performance in a compact and economical package. Capable of erecting and sealing a wide range of carton sizes at speeds up to 60 cycles per minute, the affordable 15DZ is ideal for the most demanding and cost conscious production environments. Fast changeover, simple operation and ergonomic design really set this machine apart from the crowd. Plus, if you have a challenging bag-in-box application, you'll love the special flap tucker design of the 15DZ. Like all ADCO machines, the 15DZ is constructed in stainless steel and is available in standard or washdown configurations.

### Benefits

- Stainless steel construction improves cleanability and eliminates corrosion
- Rotary carton feeder ensures smooth, efficient operation
- Special horizontal flap tucker takes the challenge out of difficult bag-in-box applications
- Large carton size range protects your investment as products change
- Ergonomically-designed product load table minimizes fatigue and maximizes productivity
- Advanced guard design keeps operators safe and maximizes maintenance access

# 15DZ Hand Load Cartoner

## Product Features

- Stainless steel construction
- Compact frame with leveling feet and casters
- Single-head rotary carton feeder
- Ergonomically-designed product load table
- Capable of sealing either tablock style or glued cartons
- Nordson® ProBlue hot melt glue system (when glue is specified)
- Allen-Bradley® control package
- Category 3 safety system with a fully-interlocked barrier guard package
- Many options available upon request

## Typical Applications

- Flow-wrapped products
- Frozen foods
- Bag-in-box
- Baked goods
- Snack foods
- Dairy products

## Utilities

### Electrical

230/460 VAC, 3-Phase with ground (PE), 60 Hz

### Air Consumption

10 CFM @ 95 PSI



## PLAN VIEW

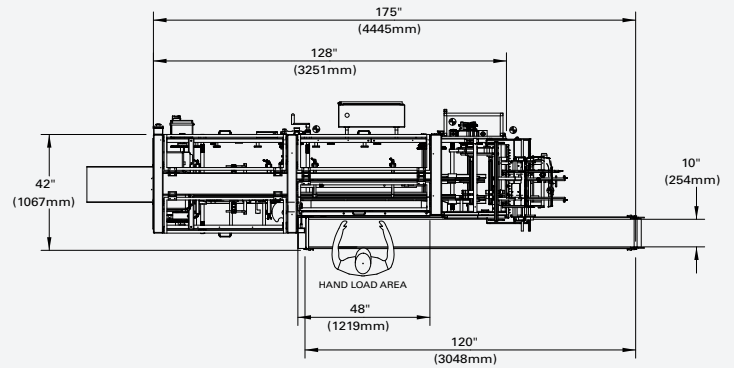

## SIDE ELEVATION

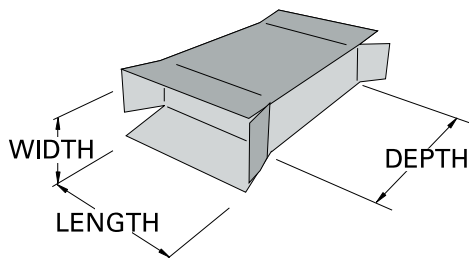
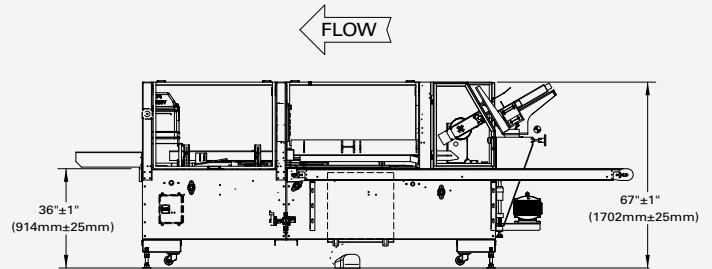

## CARTON SIZE RANGE

Dimensions	(in)		(mm)	
	Min	Max	Min	Max
Length of Opening	1	9	25	230
Width of Opening	1	4	25	100
Carton Depth	4	12	100	305

Not all minimums and maximums apply.  
Special modifications are available to extend the size range.



For more information on this product, scan the QR code with your mobile device.