

IALS

Horizontal End Load Cartoner

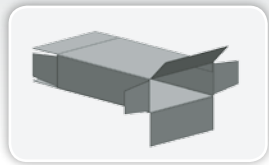
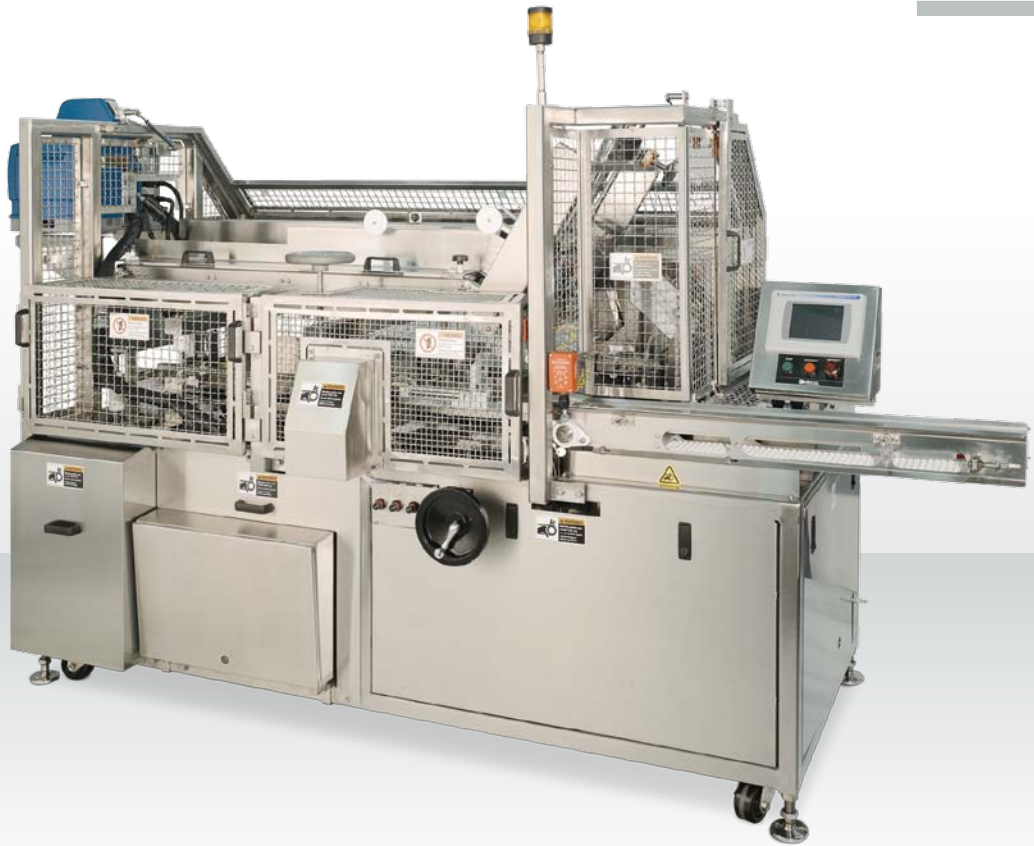

where products meet packaging™

The ADCO IALS is a compact, fully automatic horizontal end load cartoner. Originally developed to run ice cream sandwiches for the dairy industry, the intermittent motion IALS can be easily adapted to a variety of applications. At the heart of the IALS is its unique product stacking and loading system. Products are fed into the IALS at random in the broadside-leading configuration and the IALS automatically stacks and loads the grouped product into the awaiting cartons. Featuring multi-axis servo-control and construction that meets strict dairy industry standards, the reliable IALS is ideal for the most demanding production environments. The simple to operate, ergonomically friendly and easy to maintain IALS is the perfect addition to your packaging line. Like all ADCO machines, the IALS is constructed in stainless steel and is available in standard or washdown configurations.

Benefits

- Stainless steel construction improves cleanability and eliminates corrosion
- Unique, adjustable product stacker and loader maximizes flexibility and protects investment
- Pick and place carton feeder ensures smooth, efficient operation
- Fast, easy changeover with digital indicators on all adjustments reduces downtime
- Compact frame with leveling feet and casters saves space and maximize portability
- Advanced guard design keeps operators safe and maximizes maintenance access

IALS Horizontal End Load Cartoner

Product Features

- Stainless steel with severe duty washdown construction
- Intermittent motion, multi-axis servo drive system
- Compact frame with leveling feet and casters
- Horizontal powered easy-to-load carton magazine
- East to adjust product stacker and loader
- No product/no carton, no carton/no load sensing
- Powered side discharge belts and unloaded product chute
- Nordson® ProBlue hot melt glue system
- Allen-Bradley® control package with touch screen HMI interface
- Category 3 safety system with fully-interlocked barrier guard package
- PackML programming
- Many options available upon request

Typical Applications

- Ice cream bars
- Flow-wrapped products
- Snack Foods
- Baked goods
- Frozen foods

Utilities

Electrical

230/460 VAC, 3-Phase with ground (PE), 60 Hz

Air Consumption

10 CFM @ 95 PSI

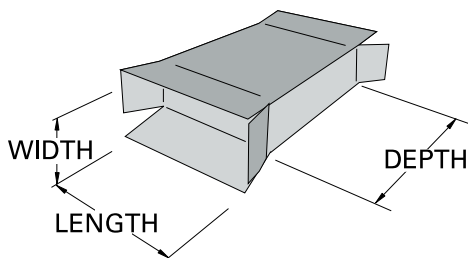
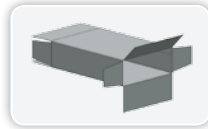

PLAN VIEW

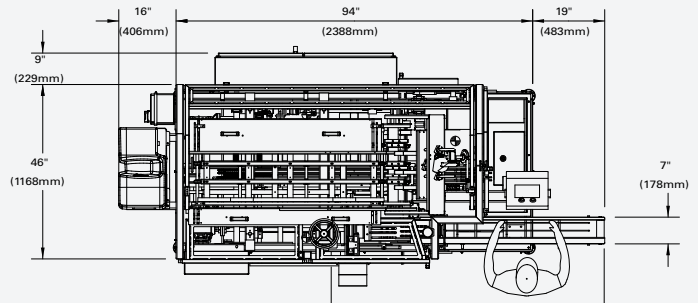

SIDE ELEVATION

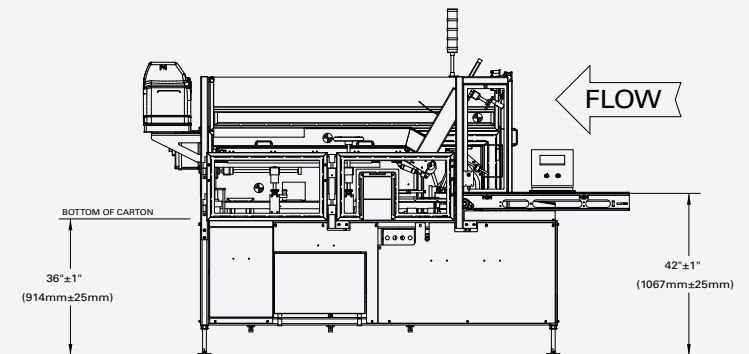

CARTON SIZE RANGE

Dimensions	(in)		(mm)	
	Min	Max	Min	Max
Length of Opening	1	9	25	229
Width of Opening	.75	4	20	100
Carton Depth	4	12	100	305

Not all minimums and maximums apply.
Special modifications are available to extend the size range.



For more information on this product, scan the QR code with your mobile device.